



UD TRUCKS

UD2600LP



North America

UD2600LP

STANDARD SPECIFICATION

MODEL		UD2600LP E	UD2600LP H	UD2600LP K	UD2600LP M	UD2600LP N	UD2600LP R	UD2600LP S
DIMENSIONS Unit: in.								
Wheelbase † (WB)		147.64	177.17	192.91	208.66	218.50	238.19	253.94
Cab-to-Rear Axle (CA)		114.92	144.45	160.20	175.94	185.79	205.47	221.22
Rear Overhang (RO)		47.64	72.83	76.97	88.58	102.36	110.24	114.17
Overall Length (OL)		246.85	301.57	321.46	348.82	372.44	400.00	419.69
Frame End Height (FEH)								
Leaf Suspension		39.14	39.44	39.40	39.49	39.64	39.62	39.57
Air Suspension		-----	37.15	37.14	37.19	37.28	37.28	37.26
Typical Body Lengths (ft.) ‡		14/16	16/18	18/20	20/22	24/26	26/28	28/30
WEIGHTS Unit: lb.								
GVWR		25,995	25,995	25,995	25,995	25,995	25,995	25,995
Chassis Weight 245hp	Front	6,315	6,495	6,620	6,680	6,735	6,785	6,870
	Rear	3,770	3,770	3,745	3,800	3,860	3,910	3,935
	Total	10,085	10,265	10,365	10,480	10,595	10,695	10,805
Gross Payload *		15,910	15,730	15,630	15,515	15,400	15,300	15,190
Chassis Weight 280hp	Front	6,535	6,720	6,840	6,900	6,960	7,005	7,095
	Rear	3,750	3,850	3,825	3,880	3,940	3,995	4,020
	Total	10,390	10,570	10,665	10,780	10,900	11,000	11,115
Gross Payload *		15,605	15,425	15,330	15,215	15,095	14,995	14,880
TURNING RADIUS Unit: ft.		21.3	25.3	27.2	29.2	30.5	33.1	35.1

* Gross payload capacity equals GVWR minus chassis weight. Installation of specialized equipment or bodies may require frame reinforcement. † Wheelbase selection should be based on specific weight distribution. ‡ Typical body lengths assume water level load (no specific consideration for driver, passengers, or fuel) to maximize GVWR. Addition of ancillary equipment such as lift gates and refrigeration units not considered in calculations.

UD2600LP Specification Diagrams

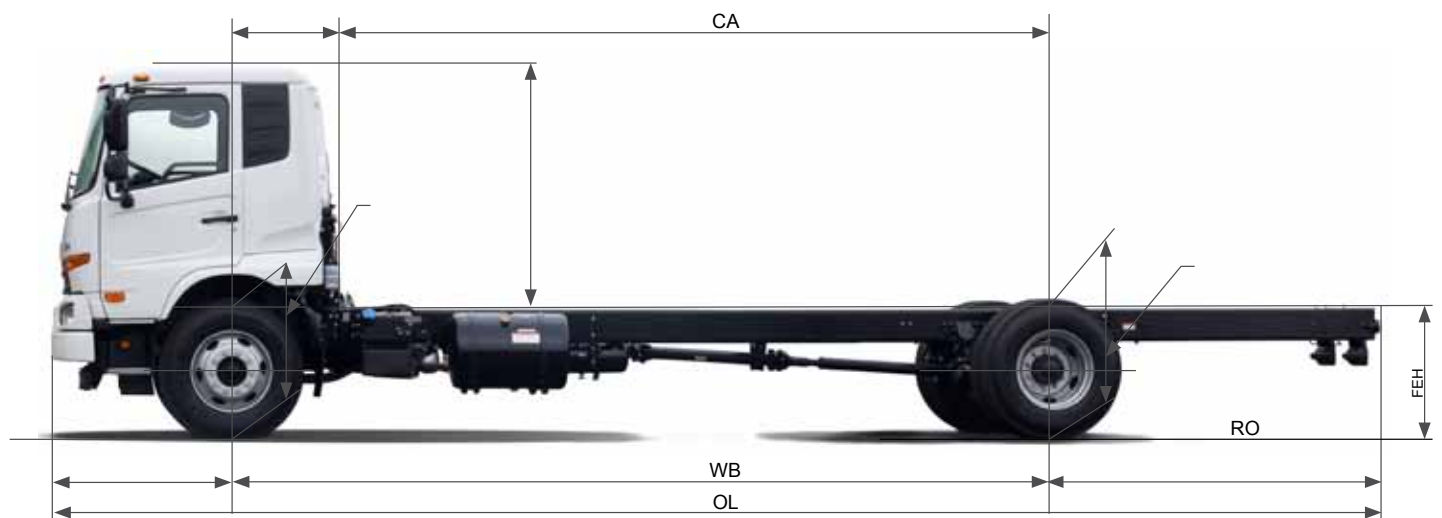
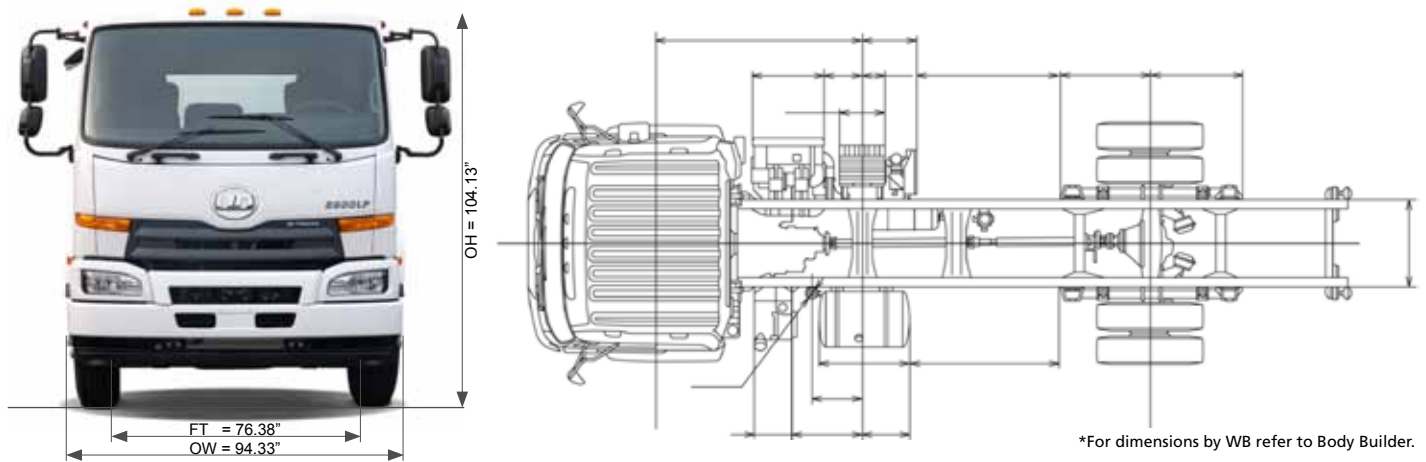

UD2600LP

ENGINE	GH7
	L6 OHC 24 Valves
	Turbo/Intercooled Diesel
	In-line 6 Cylinder, Direct-injection
Horsepower	245 hp @ 2,500 rpm * OPTION : 280 hp
Torque	530 lb. ft. @ 1,400 rpm * OPTION : 650 lb. ft.
Displacement	427 in. ³ (7.0 L)
Cylinder Liner	Dry, Replaceable
Air Compressor	12.4 CFM @ 2,600 Engine rpm (Nominal)
Fuel System	Electronically Controlled Common Rail System
Air Cleaner	11 in., Paper Filter Type (DONALDSON)
Cold Starting Aid	Automatic Electric Air Preheater
Fan	Viscous Type Drive
Battery Cold Crank Amps	565 amp (x2 = 1,130 amps) / 95D31R
Alternator	160 amp

CHASSIS FRAME	Ladder Type, Channel Section Side Rail
Dimensions (in.)*	9.84 x 3.15 x 0.31
Assembled Width (in.)	33.9
Section Modulus (in. ³)	13.3
Yield Strength (psi)	51,200
RBM (in. - lb.)** Per Rail	681,000

* Height x Flange Width x Thickness

** Minimum across load platform

Refer to current Body Builder for additional details

FRONT AXLE	
GAWR	11,020 lb.
Axle Type	"1" Beam
Suspension	Semi-elliptic Leaf Springs
Shock Absorbers	Telescopic Type

REAR AXLE	
GAWR	20,280 lb.
Axle Type	Full-floating Banjo Housing
Suspension	Semi-elliptic Leaf Springs with Auxiliary Springs

TIRES	Front: Single, Highway Tread
	Rear: Dual, Highway Tread
	255/70R22.5 - 14PR (Tubeless Radial)
WHEELS	Steel Disc Type, 10 Hole, 22.5 x 8.25 in., Offset 6.50 in.

CAB	Forward Control, Steel Construction, Tilting Cab; Cab Suspension with Shock Absorbers
Air Conditioner	Standard
Cab Glass	Windshield, Tinted Laminated, 2,273 in. ²
Cruise Control	Standard
Driver's Seat	Height & Seat Back Angle, Adjustable Lumbar w/Air Suspension, Cloth Cover, High Back Type
Passenger Seat	Seat Back Angle Adjustable, Cloth Cover, High Back
Keyless Entry	Standard
Power Windows & Door Locks	Standard
Seat Belts	Driver & Passenger, 3-Point ELR Type
Rearview Mirrors	West Coast Type, 14.2 x 7.3 in. Convex Type, 7.1 x 7.1 in. Convex Type (Side), 7.1 x 11.8 in. Passenger Side Down View Mirror
Steering Column	Tilt & Telescopic Type
Sun Visors	Driver & Passenger
Windshield Wipers	Intermittent & 2 Speed

CLUTCH	Hydraulic Clutch with Air Assist
	13.8 in. Cerametallic Friction Material (15.0 in. - GH7 280HP Engine Option)
	Standard Clutch Wear Indicator

STEERING	Integral Power Steering, Gear Driven Pump
-----------------	--

TRANSMISSION	STANDARD		* OPTION		* OPTION	
	MLS63B Manual 6 Forward Speeds & 1 Reverse, Synchronesh on 2nd through 6th Gears	Allison 2200RDS Automatic* 5 Forward Speeds & 1 Reverse	MPS63B Manual** 6 Forward Speeds & 1 Reverse, Synchronesh on 2nd through 6th Gears	Allison 3000RDS Automatic** 6 Forward Speeds & 1 Reverse		
Ratios						
1st	6.718	3.102	7.027	3.490		
2nd	4.031	1.811	4.277	1.860		
3rd	2.303	1.406	2.493	1.410		
4th	1.443	1.000	1.500	1.000		
5th	1.000	0.712	1.000	0.750		
6th	0.740	-----	0.780	0.650		
Rev.	6.121	4.492	7.038	5.030		
R/A Ratio	4.88 Std	4.88 Std	4.33	4.63 Std	5.14	5.86 Std
Engine RPM @ 65 MPH	2,210	2,126	2,070	2,210	2,048	2,332
GCWR (lbs.)	40,225	26,000	50,490	53,800	59,975	64,385

* Available with GH7 245HP Engine Only

** Available with GH7 280HP Engine Only

UD2600LP

BRAKE SYSTEM

Service Brakes	Anti-lock Braking System Dual line, Air-Over-Hydraulic Brake System
Front	Internal Expanding, Two Leading Shoe, Self-Adjusting Drum Brakes Drum Diameter x Lining Width x Lining Thickness: 15.75 x 4.72 x 0.59 in.
Rear	Internal Expanding, Dual Two Leading Shoe, Self-Adjusting Drum Brakes Drum Diameter x Lining Width x Lining Thickness: 15.75 x 6.10 x 0.59 in.
Air Tanks	Supply: 641 in. ³ Front Service: 549 in. ³ Rear Service: 641 in. ³ Total: 1,831 in. ³
Air Dryer	Standard
Rear Parking Brake	Standard at Rear Wheel

EXHAUST BRAKE

Electrically Controlled,
Pneumatically Activated
Butterfly Valve in Exhaust Pipe

FUEL TANK

Round Fuel Tank, Mounted to Left Side
Capacity - 50 Gallons

DEF TANK

Capacity: 5 Gallons, W/B - E-H
(For SCR Urea Solution) 13 Gallons, W/B - K-S

ELECTRICAL EQUIPMENT

Back-up Lights
Cigar Lighter
Clearance, Identification & Position Lights
Day-time Running Lights
Halogen Headlights, 2 Lamps
Interior and Map Light
License Light
Power Outlet - 12 Volt
Side Turn Signal Lights
Stop/ Tail Lights

INSTRUMENTS

Meters & Gauges	Air Pressure Gauges Coolant Temperature Gauge Fuel Gauge, DEF Gauge Speedometer, Odometer & Trip Meter Tachometer
Gauges in Multi Display	Ash Level Gauge Coolant Temperature Gauge Engine Oil Pressure Gauge Engine Oil Temperature Gauge Soot Level Gauge Voltmeter
Warning & Indicator Lights & Buzzers	ABS Warning Light Air-Ride Suspension Warning Buzzer Automatic Transmission: -Fluid Maintenance Warning Light -Range Inhibited Warning Light Brake Warning Light Coolant Level Warning Light & Buzzer Cruise Control "ON" & "SET" Indicator Lights DEF Low Level Warning Light Engine Air Heater Indicator Light Engine Control Warning Light Exhaust Brake Indicator Light High Beam Indicator Light High Exhaust Temperature Warning Light Low Air Pressure Warning Light & Buzzer Reverse Buzzer for Automatic Transmission

INSTRUMENTS

(Continued)

Warning & Indicator Lights & Buzzers	Seat Belt Warning Light Soot Deposit Accumulation Warning Light Tilt Lock Warning Light & Buzzer Turn Signal & Hazard Indicator Light & Buzzer
Warning & Indicator Lights & Buzzers in Multi Display	Automatic Transmission: -Check Warning -Fluid Temperature Warning & Buzzer Charge Warning DEF Low Level Warning DEF Quality Warning DPF Maintenance Warning DPF Regeneration Indicator DPF Regeneration Inhibit Warning DPF System Warning & Buzzer Engine Communication Malfunction Warning Engine Derated Warning Engine Oil: -Low Level Warning & Buzzer -Pressure Warning & Buzzer -Temperature Warning & Buzzer Engine Overrun Warning & Buzzer Engine System Warning & Buzzer Idle Shutdown Warning & Buzzer Meter Communication Malfunction Warning Overheat Warning & Buzzer Starter Overheat Warning Transmission PTO Indicator Vehicle Electrical System: -Communication Malfunction Warning -Malfunction Warning
Other Functions in Multi Display	Automatic Transmission: -O/D OFF Indicator Light -Power Mode Indicator Light -Shift Position Indicator Light Calendar Diagnostics (for EMS, VECU, NICU) Hour Meter/ Trip Hour Meter Maintenance Inspection Odometer/ Trip Meter Operation Control
Other Functions	Illumination Control

OPTIONS

Factory	Locking Cap DEF Tank Non Spin Differential Power Mirrors Power/ Heated Mirrors Rear Shock Absorbers (n/a with Air Suspension) Traction Tires
Port	90 Gallon Fuel Tank - Aluminum (K-S WB) AM/FM Stereo Radio with CD Center Console/ Third Seat

All illustrations, specifications and descriptions in this specification are based on the latest product information available at the time of this publication. The right is reserved to make changes in price, materials, equipment, design, specifications, diagrams and models, and to discontinue models of equipment at any time, without notice and without incurring any obligation whatsoever. For more information on additional options and accessories, contact UD Trucks North America, Inc.

Manufacturer:
UD Trucks Corporation
Saitama, Japan
www.udtrucks.com

Distributor:
UD Trucks North America, Inc.
www.udtrucksna.com

Department:	Sales
Section:	Specifications
Model:	UD2600LP
Model Year:	2011
Effective Date:	2/14/2011
Form #:	UDSPEC-26L
Rev #:	5